

TXR ID

TECHNICAL MANUAL



Rev.

TEXA

ENGLISH.....5

SUMMARY

1	REVISION OF THE MANUAL	5
2	INTRODUCTION	6
3	LEGEND OF THE SYMBOLS USED	7
4	SAFETY RULES	9
4.1	Intended Use	9
4.2	Glossary	9
4.3	General Rules	10
4.4	Operator Safety	11
4.5	Tool Safety	13
5	OPERATION OF THE RADIO DEVICES	15
6	ENVIRONMENTAL INFORMATION	16
7	NORMATIVE INFORMATION	17
8	TXRiD	18
9	DESCRIPTION	19
10	TECHNICAL FEATURES	21
11	POWER SUPPLY	23
11.1	Power supply from the Mains	23
11.2	Power supply from battery	25
11.2.1	Battery recharge	26
12	POWER ON/OFF	27
12.1	Power on	28
12.2	Shutdown and Standby	29
12.3	Forced Shutdown	30
13	COMMUNICATION	31
14	PREPARING FOR USE	32
15	USE	33
16	UPDATE	34
17	ACCESSORIES	36
17.1	Printer	36
18	MAINTENANCE	40
18.1	Replacing the Air Filter	41

18.2	Battery Replacement.....	43
18.3	Replacing the Flexible Hose - Oil Separator Filter.....	46
18.4	General Cleaning of the Tool.....	47
19	SOLUTIONS TO PROBLEMS.....	48
20	LEGAL NOTICES.....	49

1 REVISION OF THE MANUAL

This document is the technical manual for the product: TXRiD

Document Review Number: 02

Date of Issue: 07/06/2024

INFORMATION	<i>This manual is an essential part of the product and accompanies it from its birth up to its discontinuation.</i>
	<i>Read this manual before using the product. See the user instructions whenever the general risk symbol is shown in the product, so to understand the source of the danger and carry out the actions required to eliminate or mitigate the risk.</i>

2 INTRODUCTION

Dear Customer,

We would like to thank you for choosing a TEXA product for your workshop.

We are certain that you will get the greatest satisfaction from it and receive a great deal of help in your work.

Please read through the instructions in this manual carefully and keep it for future reference.

Reading and understanding the following manual will help you to avoid damage or personal injury caused by improper use of the product to which it refers.

TEXA S.p.A reserves the right to make any changes deemed necessary to improve the manual for any technical or marketing requirement; the company may do so at any time without prior notice.

This product is intended for use by technicians specialised in the automotive field only. Reading and understanding the information in this manual cannot replace adequate specialised training in this field.

The sole purpose of the manual is to illustrate the operation of the product sold. It is not intended to offer technical training of any kind and technicians will therefore carry out any interventions under their own responsibility and will be accountable for any damage or personal injury caused by negligence, carelessness, or inexperience, regardless of the fact that a TEXA S.p.A. tool has been used based on the information within this manual.

Any additions to this manual, useful in describing the new versions of the program and new functions associated to it, may be sent to you through our TEXA technical bulletin service.

This manual should be considered an integral part of the product to which it refers. In the case it is resold the original buyer is therefore required to forward the manual to the new owner.















Reproduction, whole or in part, of this manual in any form whatsoever without written authorization from the producer is strictly forbidden.



The original manual was written in Italian, every other language is a translation of the original manual.

© **copyright and database rights2024** The material contained in this publication is protected by copyright and database rights. All rights are reserved by law and under international conventions.

3 LEGEND OF THE SYMBOLS USED

Some of the symbols indicated below may not be used in the manual.

	Toxic material hazard		Laser beam hazard
	Explosive material hazard		Low temperature danger - freezing
	Electric shock hazard		General Risk
	Electromagnetic field hazard		Obligation to read the instructions
	Flammable material hazard		Safety glasses required
	Hot surface hazard		Protective gloves required
	Corrosive substance hazard		Protective clothing required
	Risk of noise level above 80 dB(A)		Respiratory protection required
	Moving Parts Risk		Disconnect mains plug from electrical outlet
	Risk of crushing hands		Do not wet the device
	Floor level obstacle warning		

	This is not a safety symbol. It indicates a hazardous situation which, if not avoided, will result in serious permanent injury or death.
	This is not a safety symbol. It indicates a hazardous situation which, if not avoided, may result in serious permanent injury or death.
	This is not a safety symbol. It indicates a hazardous situation which, if not avoided, may result in minor injury.

<i>NOTICE</i>	This is not a safety symbol. It indicates a hazardous situation which, if not avoided, may result in material damage.
INFORMATION	This is not a safety symbol. It indicates important information.

4 SAFETY RULES

The technology used for the design and manufacturing control of **TXRiD** makes it a reliable, simple and safe device to use.

The personnel in charge of using the tools are required to follow the general safety rules, to use the **TXRiD** devices for their intended use only and to carry out the maintenance correctly as described in this manual.

All the safety requirements issued by the following must be assessed and applied:

- *Labour inspectorate.*
- *Trade associations.*
- *Vehicle manufacturers.*
- *Anti-pollution regulations.*

in force in the country where the product is used.

4.1 Intended Use

Product	Intended Use
TXRiD	<p>Identification of the type and purity of the refrigerant fluids contained in cylinders and inside the vehicle's A/C system.</p> <p>The vehicle's A/C and climate control system must use one of the following refrigerants:</p> <ul style="list-style-type: none"> • <i>R1234yf</i> • <i>R134a</i>

4.2 Glossary

Operator: qualified person responsible for using the tool.

Tool: TXRiD

Fluid: refrigerant gas.

INFORMATION

The definition of "operator" cannot be applied to minors or to people with reduced physical, sensory or mental capabilities or without any experience or knowledge required.

4.3 General Rules



The operator must have carefully read and fully understood all the information and instructions in the technical documents provided with the tool. If the operator cannot read this manual, it is responsibility of the owner of the equipment/employer/person in charge of the safety to illustrate the contents of this document and adequately train the operator in relation to the operating instructions and safety measures for a proper use of the tool.

- *The operator that works on vehicles must have basic qualifications and knowledge of mechanics, automotive engineering, vehicle repairing and of the potential dangers that may arise during self-diagnosis operations.*
- *The operator must have basic knowledge of refrigeration, the refrigeration system, refrigerants and the potential hazards that equipment under extreme pressure can cause.*
- *The operator must be completely clear-headed and sober when using the tool; taking drugs or alcohol before or when operating the tool is strictly forbidden.*
- *The operator must follow all the instructions provided in the technical documents.*
- *The operator is required to wear adequate Personal Protective Equipment (PPE) when using the tool.*
- *The operator must monitor the tool during the operating phases wherever this is possible in compliance with the safety measures indicated below.*
- *The operator must periodically check the electrical connections of the tool, making sure they are in good condition and immediately replacing any damaged cables.*
- *The operator must periodically check the parts that are subject to wear and replace them if necessary, using only original spare parts or spare parts approved by the manufacturer.*
- *The operator must stop using the tool immediately should any failure occur, and promptly contact the technical assistance.*
- *Contact your retailer for any non-scheduled maintenance.*
- *Do not remove or damage the labels and the warnings on the tool; do not in any case make them illegible.*
- *The operator is prohibited from carrying out ANY OPERATION NOT EXPRESSLY REQUESTED AND INDICATED.*
- *The equipment can be used by children aged 8 years and above and persons with reduced physical, sensory or mental capabilities, or lack of experience or necessary knowledge, as long as they are supervised or given instructions concerning safe use of the equipment and understand the hazards involved.*
- *Children must not play with the equipment.*
- *Do not remove or tamper with any safety devices the tool is equipped with.*
- *The system assembler is responsible for the installation of systems embedded in the tool.*
- *Only use spare parts and accessories that are approved by the manufacturer.*

4.4 Operator Safety

WARNING



Using and handling refrigerant fluid may pose serious risks for your health.

Inhaling refrigerant fluid is harmful to health.

If the fluid comes into contact with the eyes, it may cause even serious visual disturbances.

Due to the low boiling temperature (approximately -30 °C) of the refrigerant fluid, it can cause cold burns when it comes into contact with the operator's skin.

For information on hazards, personal protective equipment, first aid measures, and storage, please refer to the safety sheet provided with the refrigerant fluid.

Safety Measures:

- *Wear suitable personal protective equipment such as glasses, masks and gloves that prevent direct contact with the fluid.*
- *Be very careful while handling the fluid.*
- *Turn off the vehicle engine and any compressors before connecting the tool.*

WARNING



Some refrigerant fluids are easily flammable.

The R-1234yf refrigerant is considered a flammable surface.

Vapours emitted from the combustion of the fluid may generate explosions.

Using the tool near a heat source may cause fires or explosions.

For information on hazards, personal protective equipment, first aid measures, and storage, please refer to the safety sheet provided with the refrigerant fluid.

Safety Measures:

- *Do not operate close to open flames, sparks or hot surfaces.*
- *Do not perform fluid identifications with pressures above or equal to 16 bar.*
- *Do not obstruct the GAS OUT hole in any way while using the tool.*
- *Be very careful while handling the fluid.*

CAUTION



The tool has been ergonomically designed and developed, allowing the operator to work easily and efficiently.

Moving and handling the tool inappropriately can cause the operator discomfort and physical strain.

Safety Measures:

- *To move the tool use the specific handles it is equipped with.*

CAUTION



The tool was designed and manufacturer for the specific intended use indicated in this Manual.

The tool must be used in compliance with this Manual, the documentation and any other instructions provided by the manufacturer.

Any use not compliant with these provisions expose the operator to the risk of damages and/or injuries.

Therefore, the manufacturer will not be deemed responsible for any events, even harmful, due to improper use of the tool.

Safety Measures:

- *Use the tool only in compliance with its intended use.*
- *Use the tool only based on the modes described in this manual.*
- *Do not use hoses, couplers or other accessories that are different from the ones provided with the tool and/or indicated in this manual.*

CAUTION



The tool was designed to be electrically safe and to work with specific supply voltage levels.

Improper use may expose the operator to the risk of electric shock, even though of low intensity.

Safety Measures:

- *Wear adequate personal protective equipment during all the operating phases.*
- *Do not handle or touch the tool or any accessories (e.g. cables) with wet hands.*
- *Do not open or dismantle the tool.*

WARNING



The current used during the operating phases generates Electro-Magnetic Fields (EMF) near the tool.

Even though of low intensity, these fields may interfere with medical prostheses, such as pacemakers.

Safety Measures:

- *Keep away from the tool after launching the operating phases.*
- *If you have a medical prosthesis (e.g.: pacemaker), check with your doctor as to the appropriateness of using the tool or being near it.*

4.5 Tool Safety

NOTICE



The tool was designed to be used in specific environmental conditions.

Using the tool in environments with temperature and humidity values that differ from those specified may impair its efficiency.

Safety Measures:

- *Place the tool in a dry place.*
- *Do not expose or use the tool near heat sources.*
- *Place the tool on a horizontal and stable surface.*
- *Do not expose the tool to rain or water jets.*
- *Do not use corrosive chemicals, solvents or harsh detergents to clean the tool.*
- *Always restore the tool after use.*

NOTICE



The tool was designed to be mechanically sturdy and suitable for use in the workshop.

Careless use and excessive mechanical strain may impair its efficiency.

Safety Measures:

- *Do not drop, shake or bump the tool.*
- *Do not place the tool on hot vehicle parts.*
- *Do not place objects over the cables and do not bend them.*
- *Do not perform any kind of intervention that may damage the tool.*
- *Do not open or dismantle the tool.*
- *To move the tool use the specific handles it is equipped with.*

NOTICE



The tool was designed to be electrically safe and to work with specific supply voltage levels.

Failure to comply with the specifications related to the power supply may impair the tool's efficiency.

The provided power adapter can overheat while recharging the battery.

Safety Measures:

- *Do not wet with water or other liquids.*
- *The power supply of the tool must be always connected according to the procedures indicated in the present manual.*
- *Never use external batteries to power the tool.*
- *Disconnect the power adapter in case of overheating and let it cool down between one charge and the other.*
- *Wear the most suitable personal protective equipment to avoid static electricity.*

CAUTION



Using the tool not in compliance with the indications provided in this manual may alter its manufacturing technical and safety features.

Any contamination with refrigerant fluids that are different from the ones indicated in this manual may severely damage the A/C system in the vehicle and the tool itself.

Safety Measures:

- *Carefully follow the indications provided in the technical documents.*
- *Use the tool on vehicles or cylinders containing the fluids indicated in this manual.*
- *Do not mix different fluids.*
- *Avoid prolonged exposure of the tool to external chemical agents (for example: engine oil, hydraulic oil, brake fluid).*

5 OPERATION OF THE RADIO DEVICES

Wireless connection with Bluetooth, Wi-Fi and 2G / 3G / 4G technology

The wireless connectivity with the Bluetooth, WiFi and 2G / 3G / 4G technology is a technology that supplies a standard, reliable method to exchange information between different devices, using radio waves. Other than TEXA tools, many more products use this technology, such as cellular phones, portable devices, computers, printers, photo cameras, Pocket PCs, etc.

The Bluetooth, WiFi and 2G / 3G / 4G interfaces look for compatible electronic devices according to the radio signal they emit and establish a connection between them. TEXA tools select and only prompt you with compatible TEXA devices. This does not exclude the presence of other sources of communication or disturbance.

THE EFFICIENCY AND QUALITY OF BLUETOOTH, WiFi AND 2G / 3G / 4G COMMUNICATION MAY BE INFLUENCED BY THE PRESENCE OF RADIO DISTURBANCE SOURCES. THE COMMUNICATION PROTOCOL HAS BEEN DEVELOPED TO MANAGE THESE TYPES OF ERRORS; HOWEVER, IN THESE CASES COMMUNICATION MAY BECOME DIFFICULT AND CONNECTION MAY REQUIRE SEVERAL ATTEMPTS.

SHOULD THE WIRELESS CONNECTION ENCOUNTER SERIOUS PROBLEMS THAT MAY COMPROMISE A REGULAR COMMUNICATION, THE SOURCE OF THE ENVIRONMENTAL ELECTROMAGNETIC INTERFERENCE MUST BE IDENTIFIED AND ITS INTENSITY REDUCED.

Position the tool so that the radio devices it is equipped with can work properly. In particular, do not cover it with any shielding or metallic materials in general.

6 ENVIRONMENTAL INFORMATION



Do not dispose of this product with other undifferentiated solid waste.
For information regarding the disposal of this product please see the pamphlet supplied.

7 NORMATIVE INFORMATION

	<p>The manufacturer, TEXA S.p.A., declares that the radio equipment type TXRiD is compliant with the following directives:</p> <ul style="list-style-type: none">• <i>RED 2014/53/EU</i>• <i>RoHS 2011/65/EU and Delegated Directive 2015/863/EU</i> <p>The complete text of the EU declaration of conformity is available at the following Internet address http://www.texa.it/download.</p>
---	---

	<p>The manufacturer, TEXA S.p.A., declares that the radio equipment type TXRiD is compliant with the following regulations:</p> <ul style="list-style-type: none">• <i>Radio Equipment Regulation 2017 No. 1206</i>• <i>RoHS Regulation 2012 No. 3032</i> <p>The complete text of the UK declaration of conformity is available at the following Internet address http://www.texa.it/download.</p>
---	--

8 TXRiD

TXRiD is a portable tool that identifies the type and purity of the refrigerant fluids contained in cylinders and inside the vehicle's A/C system.

A fluid that is NOT pure may cause corrosion in the components and even serious faults in the vehicle's A/C system.

The refrigerants that can be identified are:

- *R1234yf*
- *R134a*

The tool is equipped with a 5" LCD touch screen that allows performing the identification of the refrigerant without being connected to a display unit.



The tool is provided in a robust and practical case complete with:

- *fluid sample hose R1234yf;*
- *fluid sample hose R134a;*
- *power adapter;*
- *built-in and rechargeable lithium battery;*
- *technical documents.*

The provided batteries allow powering the tool without the use of cables, making it therefore easy to move the tool from one work area to another.

9 DESCRIPTION

TOOL

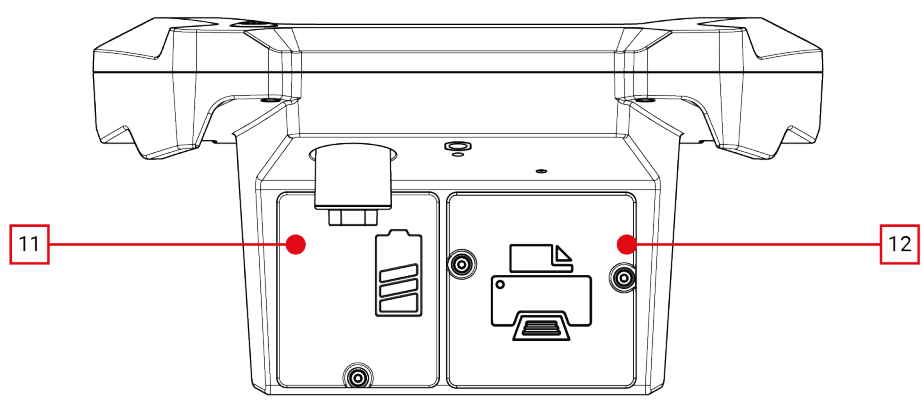
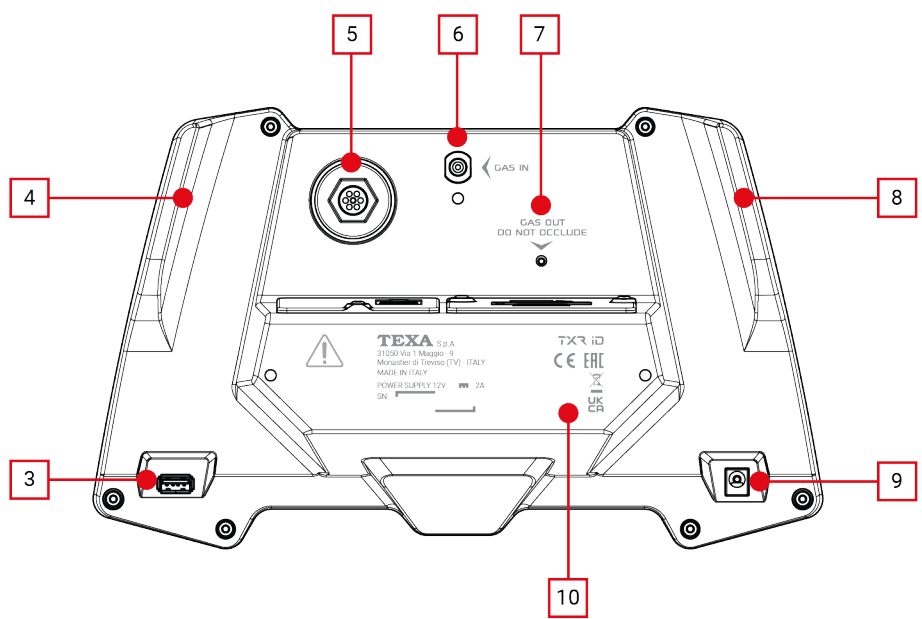
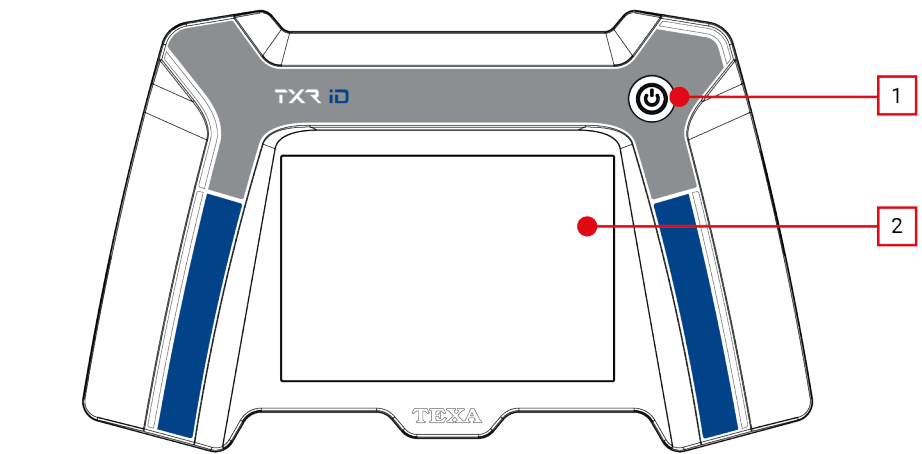

- 1. ON/OFF button
- 2. Touch display
- 3. USB connector
- 4. Handle
- 5. Air filter
- 6. GAS IN
- 7. GAS OUT
- 8. Handle
- 9. Connector for external power adapter
- 10. Data plate
- 11. Battery compartment
- 12. Printer compartment¹

POWER ADAPTER

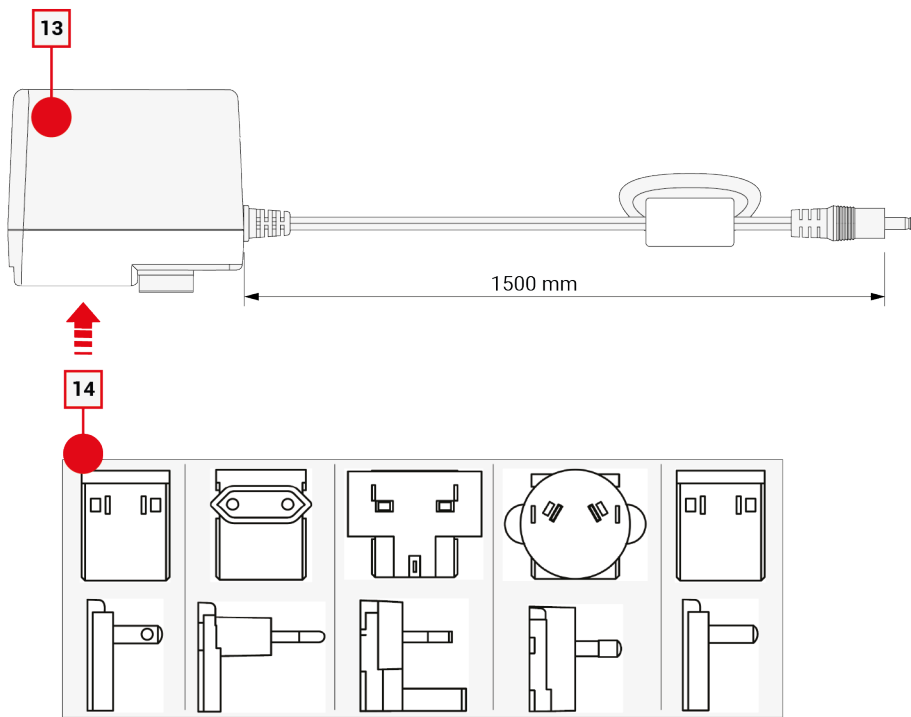

13. External power adapter

14. Plug for external power adapter²

SAMPLE HOSE³

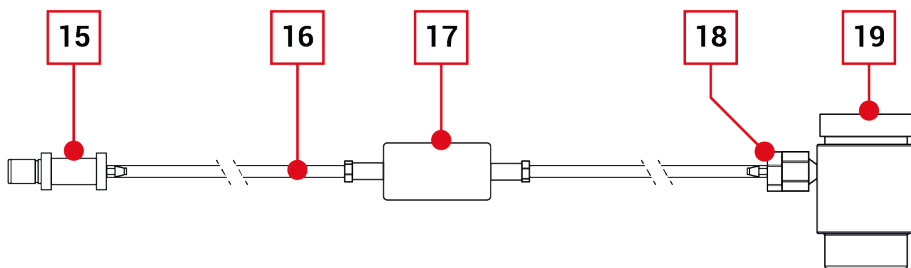

15. GAS IN fitting

16. Hose

17. Oil separator filter

18. Pressure damper

19. LP coupler





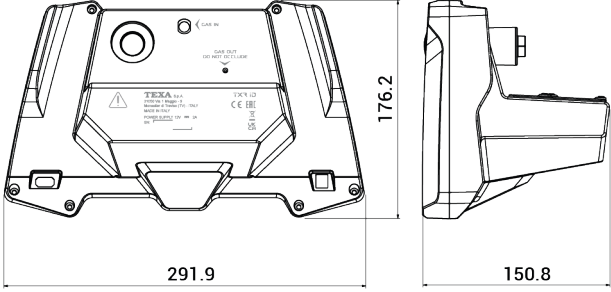

(¹) The thermal printer is an accessory that can be purchased separately.

(²) The power adapter is supplied with a set of interchangeable plugs.

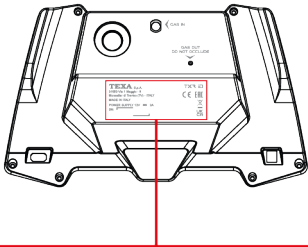
(³) The composition of the provided sample hoses are identical, however the pressure damper and LP coupler are specific for the gas that must be analysed.

10 TECHNICAL FEATURES

Manufacturer:	TEXA S.p.A.
Product name:	TXRiD
Power supply:	12 V _{DC}
Charger:	<p>External power adapter:</p> <ul style="list-style-type: none"> • <i>Model: SMI24-12-V-P5-C3</i> • <i>Input: 100 - 240 V_{AC}; 50 - 60 Hz; 0.58 A</i> • <i>Output: 12 V_{DC} ; 2 A ; 24 W</i> • <i>Socket: IS13252 (Part 1) - IEC 60950-1 - R-41013177</i> • <i>Cable: UL 2468; 20 AWG</i>
Internal battery:	2 lithium-ion cells without gas gauge with NTC 3350 mAh 7.4 V
Absorption:	max 2 A
Operating temperature:	10 ... 50 °C
Storage temperature:	-20 ... 50 °C
Humidity:	10% ÷ 80% RH* (* <i>without condensation</i>)
Operating frequency band:	2400 ÷ 2483.5 MHz
Maximum radio frequency power transmitted:	10 dBm
Dimensions:	
Weight:	1.2 kg
USB output:	5 V _{DC} ; 500 mA max Functional isolation
IP level:	IP 2X

Environmental conditions:	<ul style="list-style-type: none"> • <i>Use: internal</i> • <i>Altitude (up to): 2000 m</i> • <i>Supply voltage fluctuations: $\pm 10\%$</i> • <i>Overvoltage category: II</i> • <i>Power adapter pollution degree: 2</i> • <i>Tool pollution degree: 3</i> • <i>Maximum relative humidity 80% for temperatures up to 31 °C, linearly decreasing to 50% at 50 °C</i>
Directives:	RED 2014/53/EU RoHS 2011/65/EU and Delegated Directive 2015/863/EU
Regulations:	Radio Equipment Regulation 2017 No. 1206 RoHS Regulation 2012 No. 3032
Electromagnetic compatibility:	ETSI EN 301 489-1 ETSI EN 301 489-17 EN 61326-1
Radio systems:	ETSI EN 300 328
Electrical Safety:	EN 61010-1 EN 62311
Data Plate:	<div style="text-align: center;">  </div> <div style="border: 1px solid red; padding: 10px; margin: 10px auto; width: fit-content;"> <div style="display: flex; justify-content: space-between; align-items: center;"> <div style="text-align: center;">  </div> <div style="text-align: center;"> <p>TEXA S.p.A. 31050 Via 1 Maggio - 9 Monastier di Treviso (TV) - ITALY MADE IN ITALY POWER SUPPLY 12V  2A SN: _____</p> </div> <div style="text-align: center;"> <p>TXR iD   </p> </div> </div> </div>

11 POWER SUPPLY

The tool can be powered:

- *from the mains using an external power adapter;*
- *by internal batteries.*

INFORMATION

The presence of power supply is indicated in the display through a specific icon.

11.1 Power supply from the Mains

It is possible to power the tool by connecting it to the mains via a specific power adapter provided with the tool.

⚠ CAUTION

The use of different power adapters other than the one indicated can damage the tool and expose the operator to the risk of injuries.

The protection provided by the tool can be altered if it is not used as specified by the manufacturer.

The mains plug must be used to disconnect from the mains.

If connected to the mains, make sure the tool's power adapter plug can always be accessed in order to be able to disconnect it from the mains at any time.

Only use the charger provided with the tool:

- **Model:SMI24-12-V-P5-C3**
- **Code:3910612**

The power adapter is supplied with a series of interchangeable plugs suitable to be used with the mains power sockets in use in the different countries.

⚠ CAUTION

The use of non-compatible socket plugs may alter the tool's electrical protection and expose the operator to the risk of injuries.

Only use the plug compatible with the mains power socket the power adapter will be connected to.

Do not force a plug into a different mains power socket from the one that is officially compatible.

Proceed as follows:

1. Insert the plug in the specific housing on the power adapter.

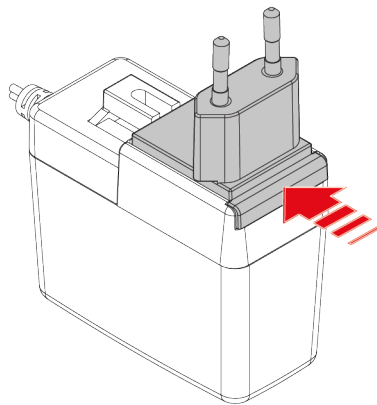

2. Connect the jack connector on the power adapter [1] to the connector for powering the tool [2].

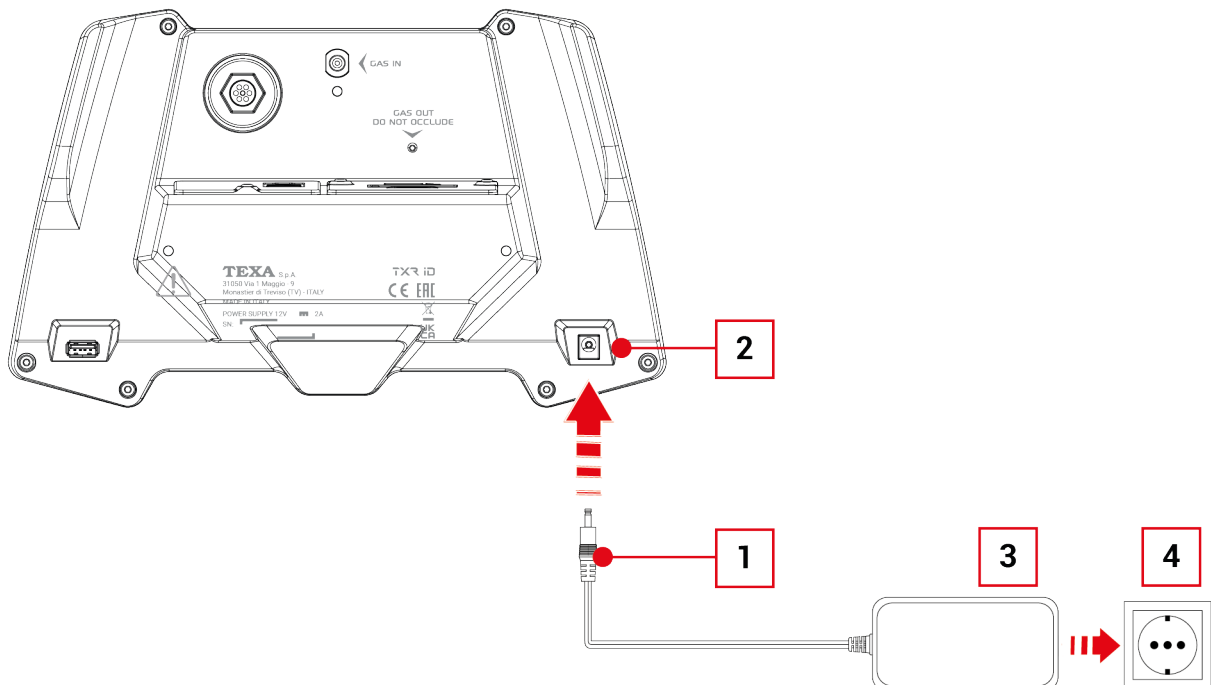

3. Connect the plug on the power adapter [3] to the mains socket [4].



11.2 Power supply from battery

The tool is powered by an internal rechargeable battery.

The battery power supply allows powering the tool without the use of cables, making it therefore easy to move the tool from one work area to another.

The battery power supply allows continuous use of the tool for approximately 5 hours.

The battery charge status is indicated through a specific icon.

Icon	Colour	Analysis	Print with:		Notes
			network printer	local printer	
	green	Allowed	Allowed	Allowed	--
	yellow	Allowed	Allowed	Not allowed	--
	red	Allowed	Allowed	Not allowed	We recommend charging the tool.

INFORMATION

The tool cannot work properly below a certain battery charge limit value.

When this value is reached the tool displays a specific screen for a few seconds requiring to charge the tool.

When the screen disappears, the tool turns off.

The shutdown causes the interruption of any activity in progress and the non-stored data is lost.

11.2.1 Battery recharge

It is possible to charge the tool by connecting it directly to the mains via a specific external power adapter.

The tool is able to work normally while being recharged.

The battery can be charged with the tool switched on or off.

The charge status is indicated by a specific icon.

Icon	Colour	Measurement	Print with:		Notes
			network printer	local printer	
	variable	Allowed	Allowed	Allowed	The colour of the icon depends on the battery charge status when the power adapter is connected and varies until becoming completely green when the charging is complete.

The charge lasts approximately:

Tool status	Charging time
off	5.5 ÷ 6.5 h
on	3.5 ÷ 5.5 h

Any failures are indicated in the tool's display.

INFORMATION

To store the tool correctly and when storing it for longer than one month, we recommend charging it completely.

We recommend charging the tool completely any time it has not been used for 2-3 months.

Once the recharge is complete, disconnect the tool from the power adapter; place the power adapter in the provided case.

CAUTION

The use of different power adapters other than the one indicated can damage the tool and expose the operator to the risk of injuries.

Only use the charger provided with the tool:



- **Model:SMI24-12-V-P5-C3**
- **Code:3910612**

12 POWER ON/OFF

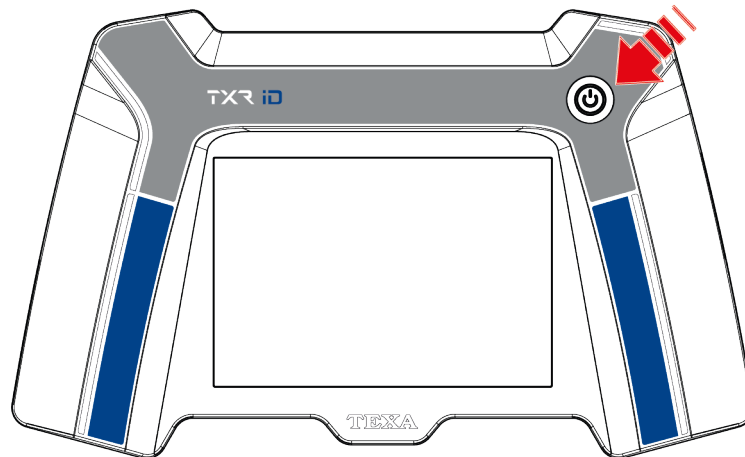
The tool's activation and deactivation is commanded pressing the ON/OFF button.



The button is back lit by a green LED through which the tool provides indications on its status.

Button	LED	Tool status	Notes
	on	on	The tool is operational.
	blinking	energy saving mode	Short period of inactivity. The tool decreases the display's brightness. Press the button to make the tool return operational. Or touch the tool's screen.
	off	standby	Extended period of inactivity. The tool turns the display off. Press the button to make the tool return operational.

INFORMATION

If after the standby mode the period of inactivity continues, the tool turns off.

The shutdown causes the loss of the non-stored data.

To restart the tool, press the ON/OFF button again.

12.1 Power on

To turn on the tool proceed as follows:

1. Keep the ON/OFF button pressed until the green LED lights up.
2. Wait for the software to start.
3. The tool is ready for use when the HOME screen appears.



**Refrigerant
analysis**



Archive

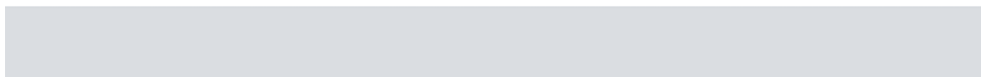

NOTICE

Turning off in other ways rather than the ones indicated may damage the tool.



Do not turn off the tool by disconnecting it from the mains.

To turn off the tool proceed as follows:

1. Keep the ON/OFF button pressed until the shutdown screen is displayed.
2. Press on the desired function.





Shut down

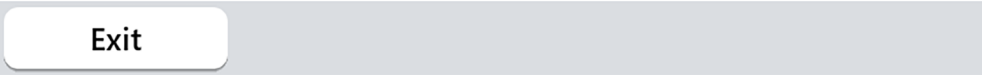

Standby



Icon	Name	Description
	Turn off	It allows you to turn off the tool.
	Suspend	It allows you to suspend the tool's operation temporarily. Press the button to make the tool return operational.

12.3 Forced Shutdown

In case of need (ex.: the software does not respond to the commands), the tool can be forced to shutdown.

INFORMATION

The shutdown causes the interruption of any activity in progress and the non-stored data is lost.

Proceed as follows:

1. Keep the ON/OFF button pressed for at least 10 seconds.

The tool switches off.

INFORMATION

There is no automatic restart.

To restart the tool, press the ON/OFF button again.

13 COMMUNICATION

The Wi-Fi module installed in the tool makes it able to:

- *connect to the Internet, to receive updates for the installed software;*
- *print the fluid identification reports on the network printer.*

INFORMATION

To be able to use the identification functions, you must have carried out the software activation procedure.

Proceed as follows:

1. *Turn on the tool.*
2. *Launch the tool's configuration function.*
3. *Follow on screen instructions*



For further information, see the software operating manual.

14 PREPARING FOR USE



CAUTION

Do not place the tool on hot surfaces.

Avoid prolonged exposure to external chemical agents.

Position the tool as close as possible to the vehicle or the cylinder, being careful to place it stably on the resting surface.

NOTICE

Make sure the tool's battery is charged.

Turn off the vehicle's engine before starting the refrigerant identification.

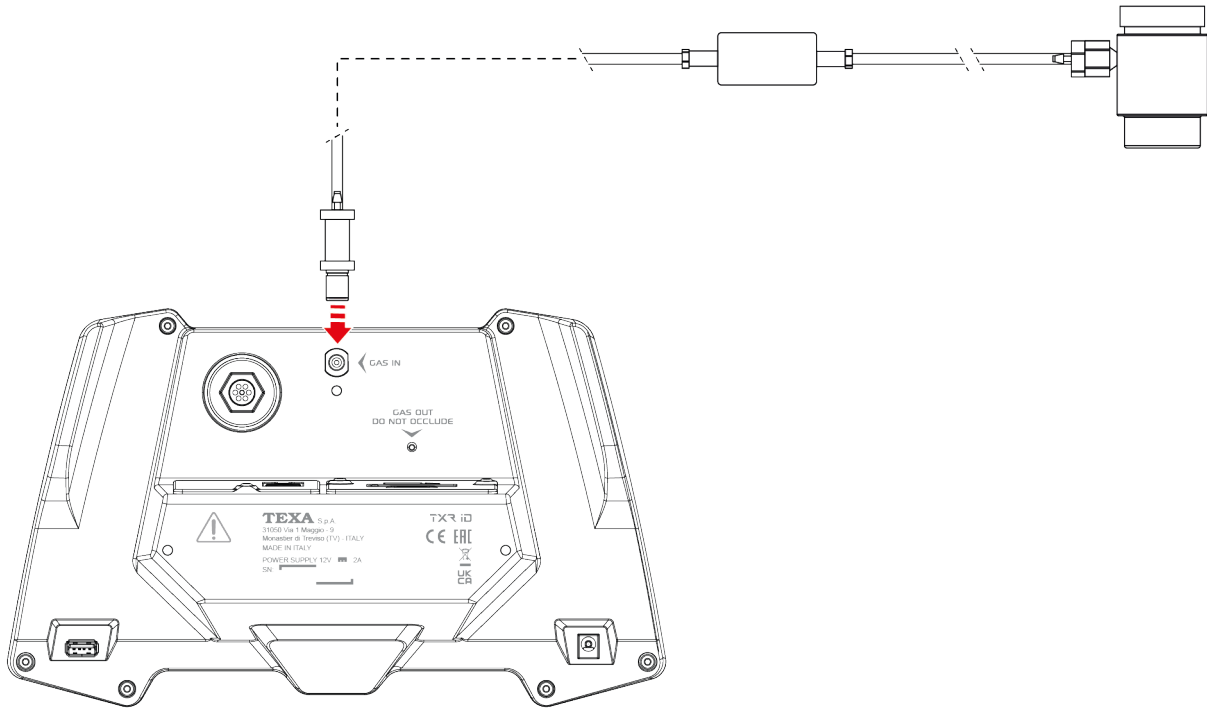

Before performing the refrigerant fluid identification, proceed as follows:

1. Select the sample hose based on the fluid that must be identified.
2. Insert the GAS IN fitting on the sample hose into the tool's **GAS IN** connector.
3. Connect the sample hose's fitting to the **LP** valve to the vehicle's A/C system or to the cylinder with the fluid that must be identified.

15 USE

The software provides on-screen indications required in order to carry out the various operations and warns if errors occur during the phases.

NOTICE



Inserting into the tool's analysis chamber refrigerant in a liquid status may compromise the analysis capability and functionality.

Only draw the refrigerant that must be identified in a gaseous status through the LP coupler (max 16 bar).

Proceed as follows:

1. Be sure to have completed all the required preliminary operations.
2. Turn on the tool.



**Refrigerant
analysis**



Archive

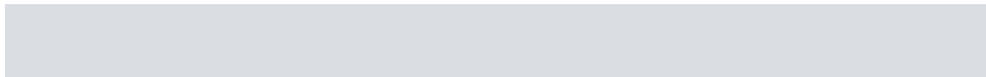

3. Press .

4. Follow the on-screen indication.



For further information, see the software operating manual.

16 UPDATE

The software in the tool updates automatically.

NOTICE

The tool must be connected to a Wi-Fi network that can access Internet to check if updates are available and eventually download them.

It is important to guarantee that the download and installation of the update can be completed without interruptions.

For this purpose:

- Keep the tool on and powered through an external power adapter throughout the entire duration of the update (download and installation).
- Keep the tool connected to the Wi-Fi network throughout the entire duration of the download.

The tool checks for updates available to be downloaded at each power on.

The download of available updates starts automatically.

The download in progress is indicated through the icon .

INFORMATION

The tool can continue to be used normally while the update is being downloaded.

The progress of the download can be checked by pressing SETTINGS > Wi-Fi.

The software requires installing the update at the subsequent restart of the tool.



Update available.

- 1). Press CONFIRM to install.
- 2). Press EXIT to continue.

Exit

Confirm

Press **CONFIRM**.

INFORMATION

No analyses or other operations can be carried out with the tool during the installation.

In some cases the software restarts the tool automatically at the end of the installation.

17 ACCESSORIES

17.1 Printer

The thermal printer is an accessory that can be purchased separately. Following is the procedure for the installation.

NOTICE

Installing the printer requires accessing the inside of the tool.

During the installation, be careful to not damage the cables needed to connect the printer or any other tool component.

NOTICE

The wiring for the installation has a label that identifies it univocally.

Use of wiring different from the one indicated may compromise the tool's functionality.

Do not use wiring different from the one indicated.

Follow the connection diagram indicated in the images below.

Proceed as follows:

1. Turn off the tool.
2. Disconnect the power cable from the tool.
3. Remove the cover from the printer compartment by unscrewing the two screws that fasten it to the tool.

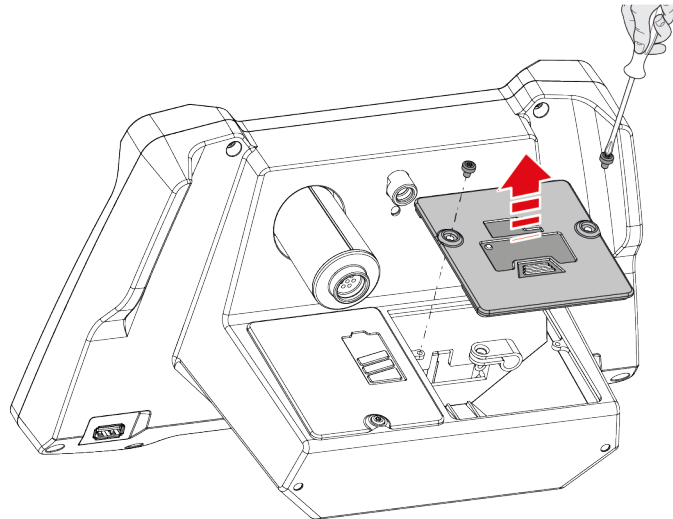

4. Remove the screw that fastens the battery compartment's cover.

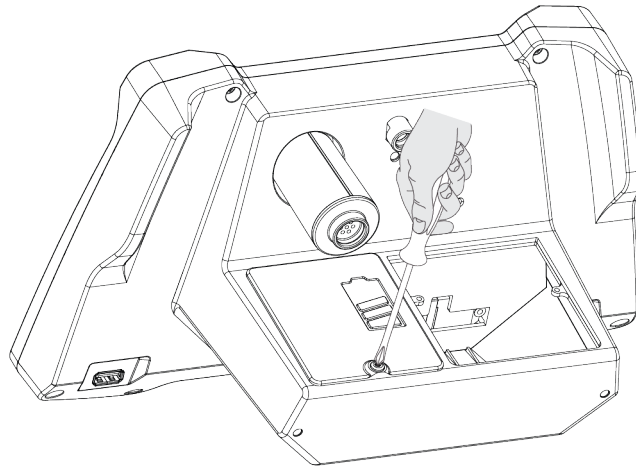

5. Remove the battery compartment cover as indicated.

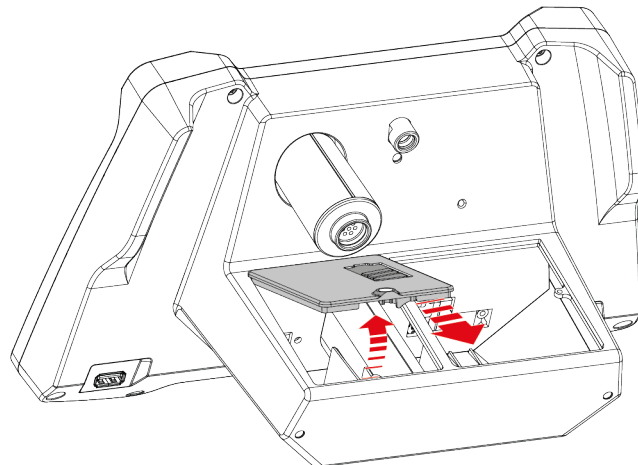

6. Disconnect the tool's power wiring from the battery.

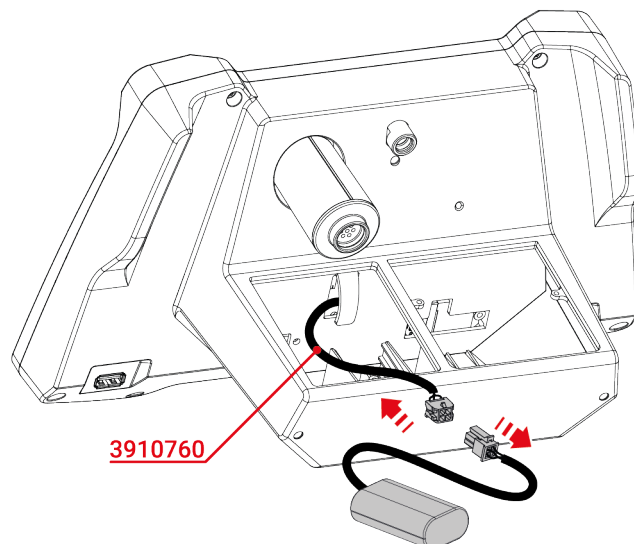

7. Connect the wiring as indicated in the image.

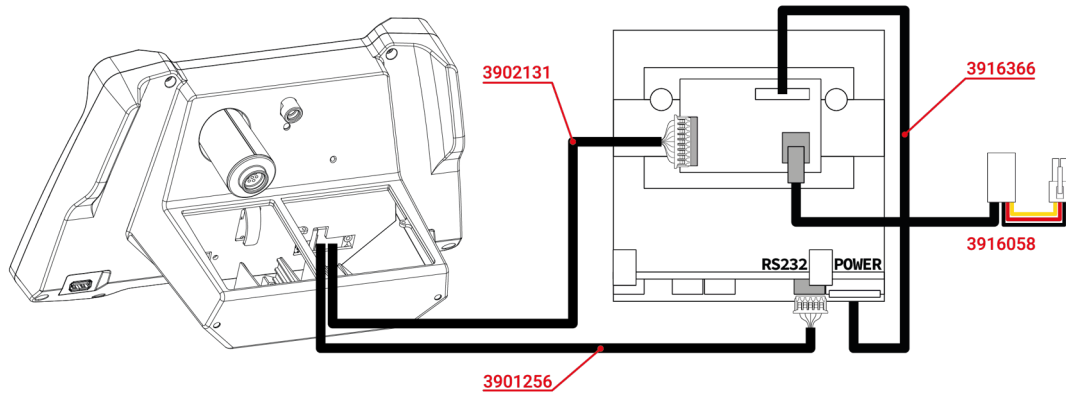

8. Reconnect the power wiring as indicated.

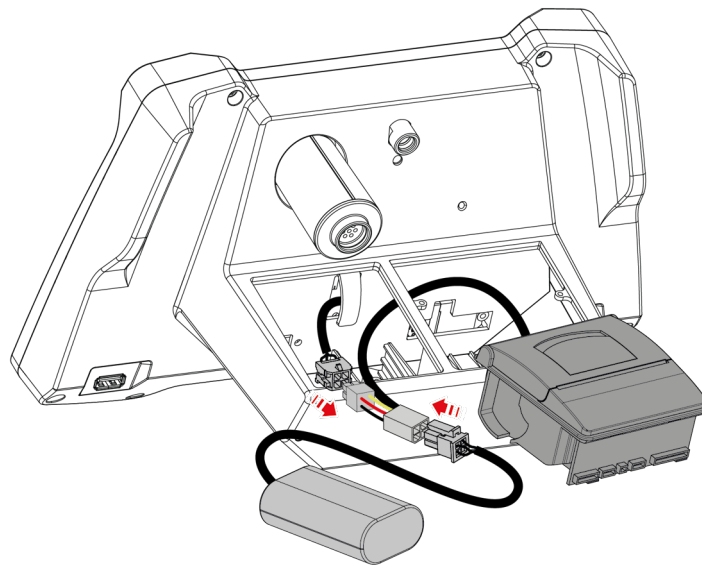

9. Place the battery and printer in their related compartments.

10. Lift the printer's flap and secure it to the tool using the two screws removed previously.

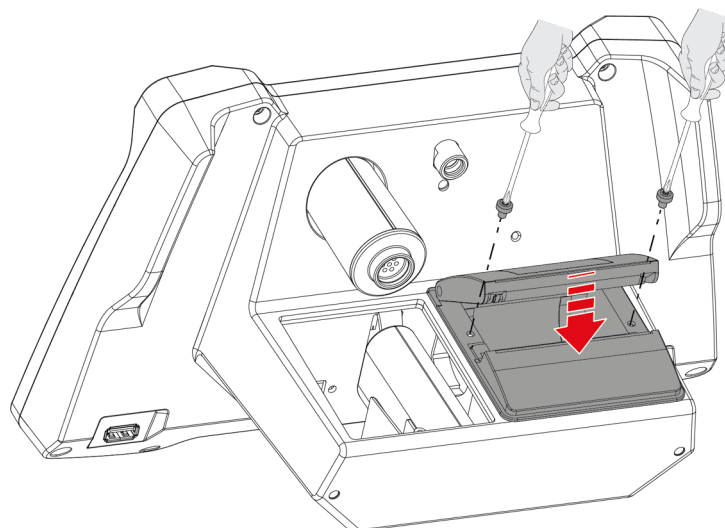

11. Remount the battery compartment's cover and secure it using the screw removed previously.

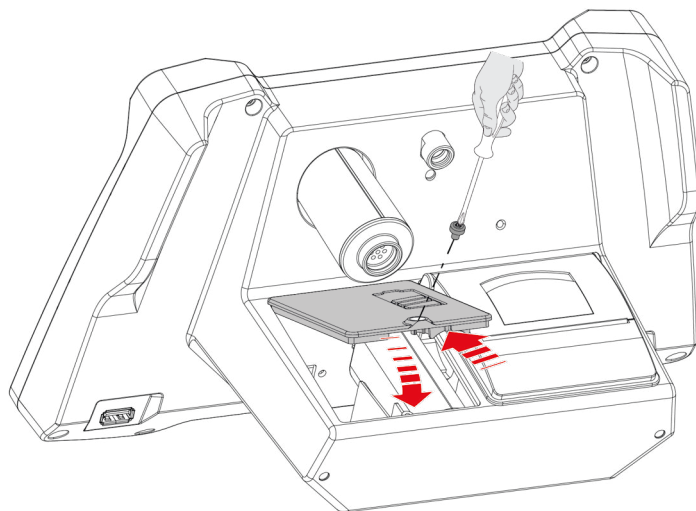

INFORMATION

The printer is automatically on-line when the tool is switched on.

18 MAINTENANCE

Below the ordinary maintenance and cleaning operations that can be carried out by the operator are described.

Component	Operation	Frequency
Air filter	replacement	when indicated by the software/once a year
Battery	replacement	when the complete charge no longer allows normal use of the tool
Flexible hose + Oil separator filter	replacement	when the filter changes colour/once a year

CAUTION



The tool works with internal voltage levels that are not a risk for the operator's life; however, they may expose the operator to the risk of minor injuries.

Carry out all the maintenance operations with the tool switched off and disconnected from the mains, except if indicated differently.

NOTICE



The use of spare parts and accessories that are not approved by the manufacturer may compromise the tool's efficiency and safety.

Only use spare parts and accessories that are approved by the manufacturer.

Contact your retailer for any maintenance operation that is not described below.

You can see the list of authorised retailers at the following address: <https://www.texa.com/sales-network>

18.1 Replacing the Air Filter

The air filter must be replaced when indicated by the software and in any case once a year.

Icon	Description
	The degree of the air filter wear is indicated by the percentage value displayed by the software beside the icon.
	The percentage value is inversely proportional to the filter wear. Ex.: <ul style="list-style-type: none"> • <i>New filter: 100 %</i> • <i>Worn-out filter: 0 %</i>

The software warns of the need to replace it through a specific message.

NOTICE

The filter's outer casing is made of plastic.

The use of wrenches or other tools to replace it may damage it making it difficult to remove it and compromise its functionality.

INFORMATION

The non-replacement of the air filter does not block the refrigerant identification process.

However it is strongly recommended to carry out the procedure in the technical manual indicated below.

Using a worn-out filter may compromise the correctness of the identification.

Proceed as follows:

1. Unscrew the filter manually.

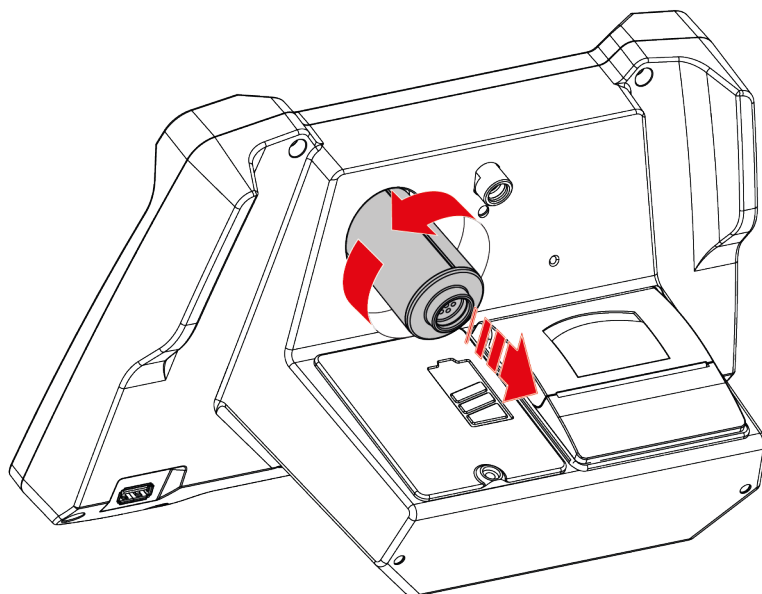

2. Screw in the new filter manually being careful not to tighten it excessively.

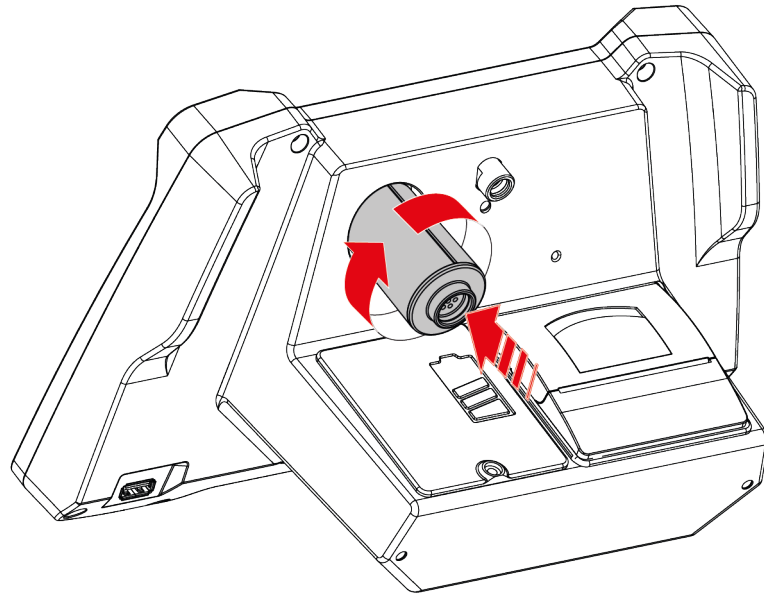

3. Turn on the tool.

4. Access the filter counter reset function:SETTINGS>FILTER RESET

5. Follow the instructions that appear on screen.



For further information see the software's Operating Manual.

18.2 Battery Replacement

The battery must be replaced when the complete charge no longer allows normal use of the tool.

Proceed as follows:

1. Unscrew the screw that blocks the battery compartment's cover.

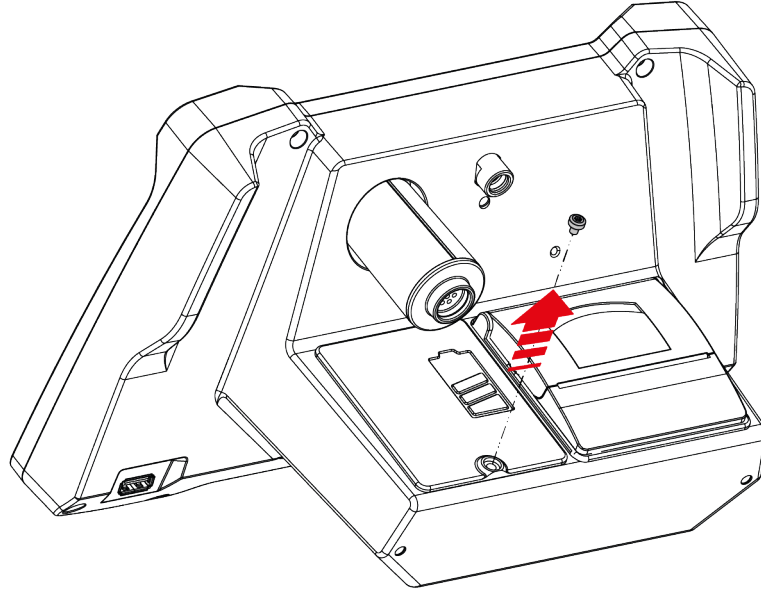

2. Remove the compartment's cover.

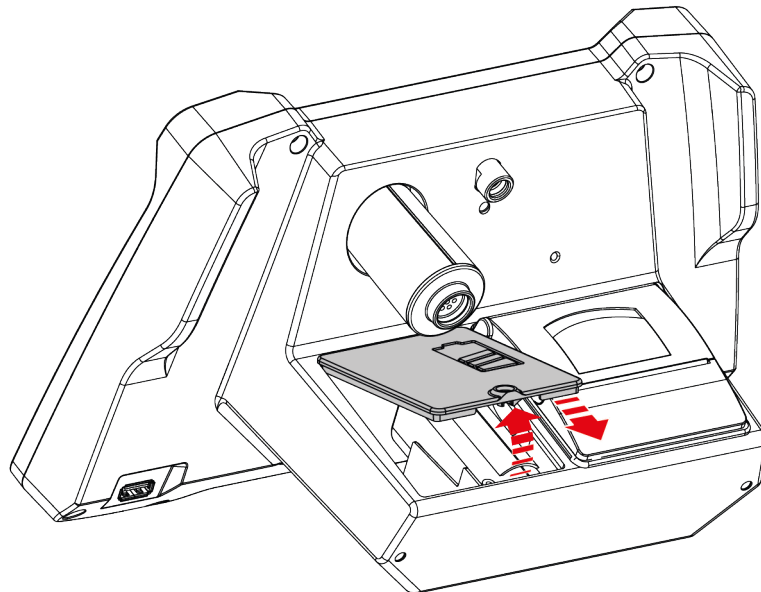

3. Delicately extract the battery from its housing being careful not to damage the wiring it is connected to.

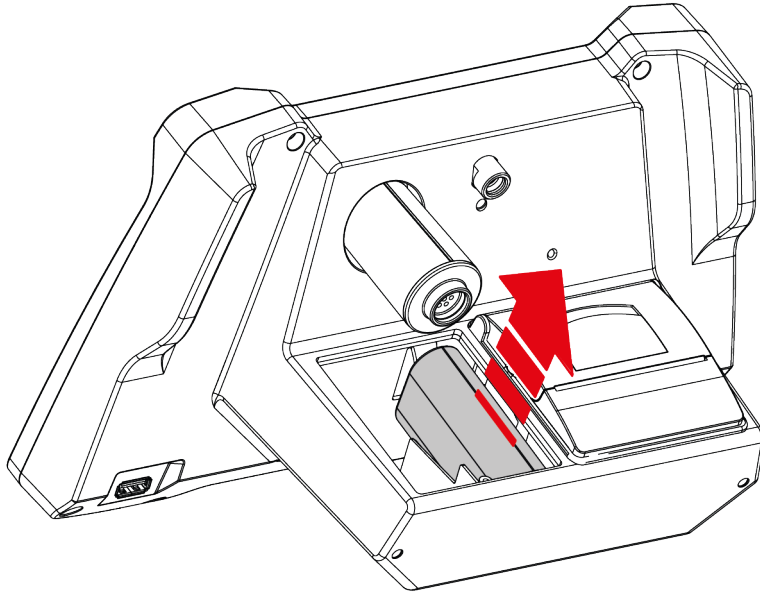

4. Disconnect the tool's power wiring from the battery.

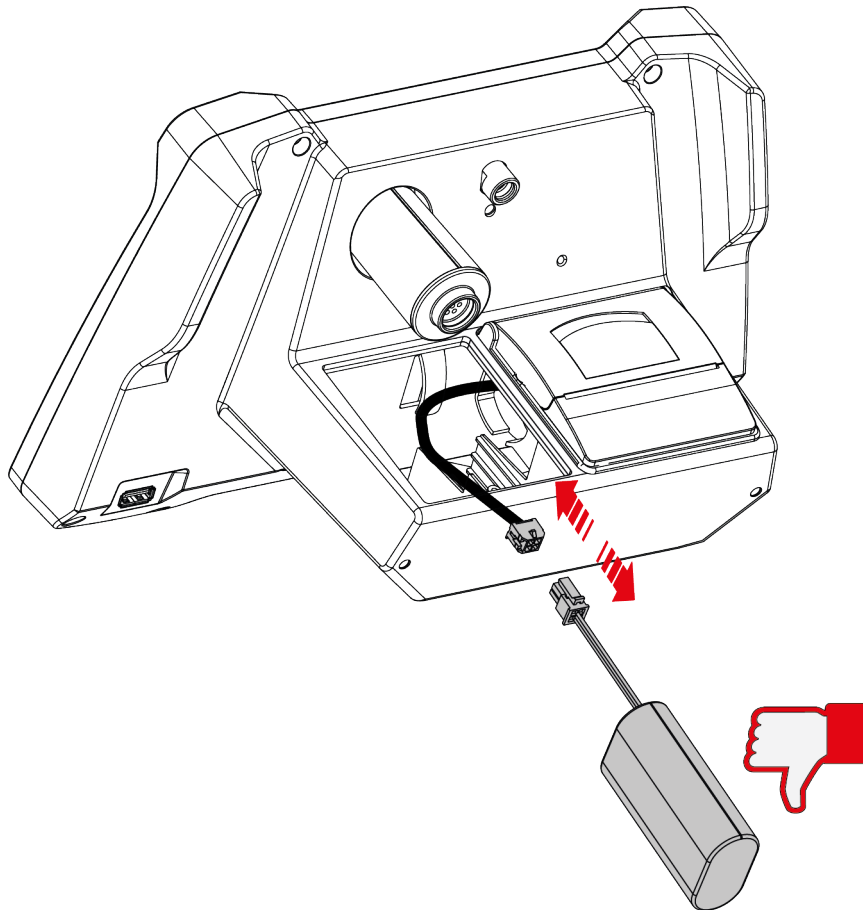

5. Connect the new battery to the tool's power wiring.

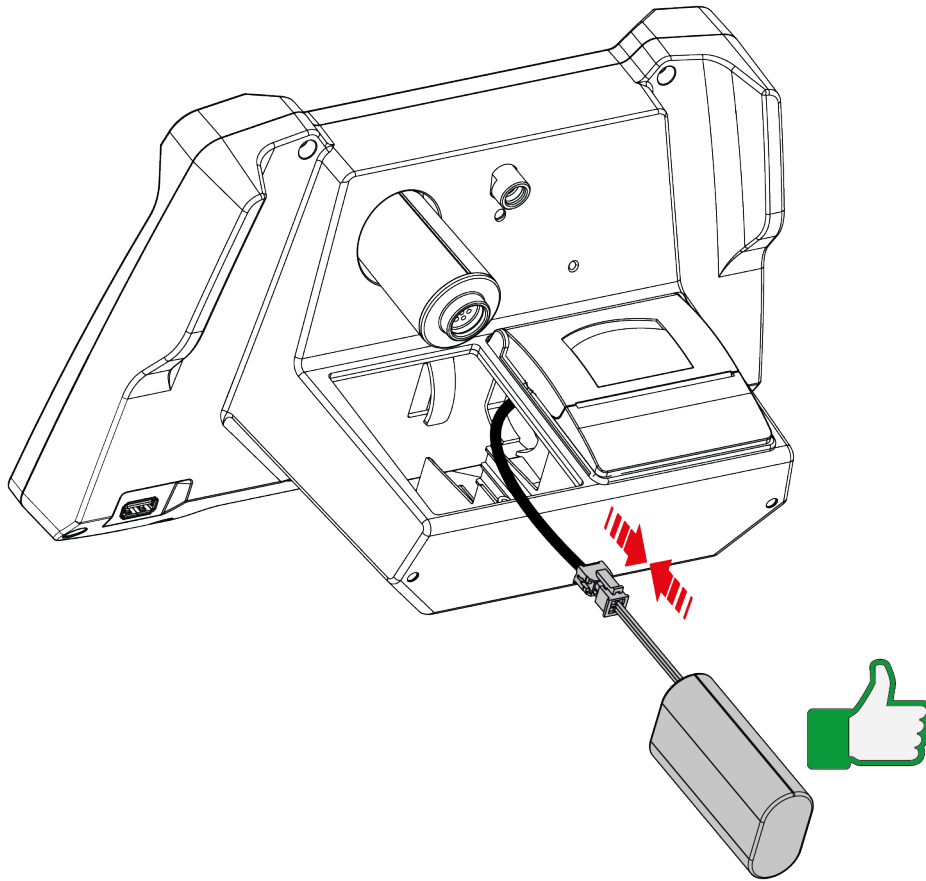

6. Place the new battery in the specific housing being careful to position the wiring properly inside the compartment.
7. Reposition the compartment's cover being careful to not pinch the power wiring and any other wiring in the compartment.
8. Screw on the screw that blocks the battery compartment's cover.

NOTICE

Dispose of the battery removed following the regulations in force in the country where the tool is used.

18.3 Replacing the Flexible Hose - Oil Separator Filter

The assembly made up of the flexible hose and the oil separator filter must be replaced when the filter is visibly dirty, changes colour or in any case once a year.

INFORMATION

The procedure indicated below is valid for both sample hoses.

Proceed as follows:

1. Disconnect the sample hose from the tool.
2. Use a pair of fork wrenches of the size required to unscrew the pressure damper from the LP coupler.

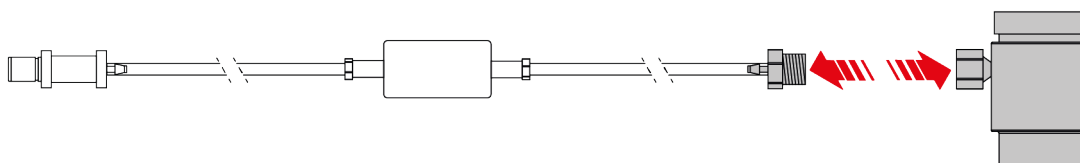

3. Remove the GAS IN fitting from the flexible hose.

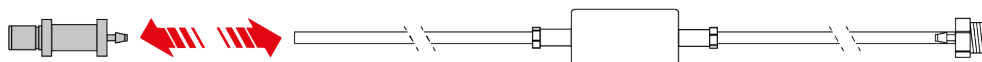

NOTICE

The hose and the fitting are firmly engaged one to the other in order to guarantee an optimal grip.

Be careful to not damage the fitting while removing the hose.

4. Firmly engage the new hose-oil separator filter assembly onto the GAS IN fitting.
5. Use a pair of fork wrenches of the size required to screw the pressure damper onto the LP coupler.

NOTICE

The pressure damper and LP coupler are specific for the fluid that must be analysed.

Do not use adapters/reducers to pair pressure dampers to non-appropriate LP couplers.

18.4 *General Cleaning of the Tool*

The tool must be kept clean.

Use a moist cloth to clean the tool.

NOTICE

Do not use corrosive chemicals, solvents or harsh detergents to clean the tool.

19 SOLUTIONS TO PROBLEMS

For any technical problem contact your retailer/distributor.

Below you will find a list of simple instructions that the client can carry out without having to ask for technical assistance.

PROBLEM	POSSIBLE SOLUTION
The tool does not turn on.	Make sure the power adapter cable is connected to the mains.
	Make sure the power adapter cable is connected to the tool.
	Make sure the electric supply service is compatible with the product and country specifications
	Recharge the tool for at least 6 hours.
	If all the conditions above are met and the problem persists, contact your distributor/retailer.
The battery runs flat very quickly.	Recharge the tool for approximately 6 hours.
	Check the wiring and make sure that the connections are correct.
	Contact your retailer to replace the batteries.
The battery is not recharging.	Connect the power supply to the mains.
	Connect the power adapter to the tool.

20 LEGAL NOTICES

TEXA S.p.A.

Via 1 Maggio, 9 - 31050 Monastier di Treviso - ITALY

Tax Code - Company Register of Treviso ID No. - VAT No.: 02413550266

Single-shareholder company subject to the direction and coordination activities of Opera Holding S.r.l.

Paid-up share capital 10.000.000 € - R.E.A. (Economic Administrative Index) No. 208102

Phone: +39 0422.791.311

E-Mail: info.it@texa.com

www.texa.com

For information regarding the legal notices, please refer to the **International Warranty Booklet** provided with the product.